

Product Datasheet



The global certified BLD-320-V series is a dual stage high efficiency smart LED driver. 2% minimum level and high frequency PWM output provides strobe flicker free user experience. 100khour long life and 7-year warranty provide high confidence to luminaire users. It supports not only traditional dimming control, but also DALI2.0 protocols. All around protections including digital OTP, SCP and OCP with auto-recovery secure 24hour non-stop operation for luminaires.

- Strip
- Light box
- Signage
- Bath
- Swimming



- Features 2
- Model List 2
- Technical Data 3
- Dimming 4
- Safety/EMC Compliance 6
- Output Voltage Setting by Pushing Button 6
- Lifetime vs. Case Temperature 7
- Power Factor vs. Load 7
- THD vs. Load 8
- Efficiency vs. Load 8
- Inrush Current 9
- Dielectric Strength 9
- Tc Point 9
- Packaging Information 10
- Mechanical Design 11
- Revision History 14

320W, Constant Voltage Adjustable Output LED Driver

■ Features

- Supply Voltage: 90-305Vac, 380Vac for 2 hours
- Great Surge Immunity 10kV
- 4kHz PWM Output Frequency
- Adjustable Output Voltage (by Push Button)
- 100,000Hour Life @ Tc=75°C
- 7 Year Warranty @ Tc<=75°C
- 0-10V/PWM/DALI2.0/Push (Switch) /DMX (RDM) Dimmable
- 2% Minimum Dimming Output
- Dim Off with 0.5W Standby
- 12V 300mA Auxiliary Power to Power Controllers and Fans (Optional)
- -60°C Ambient Operation (Optional)
- Class II Model Available
- UL Class P, ENEC/CB/CCC SELV Output
- Safety according to EN 61347-1, 61347-2-3 61347-2-13, 62384

■ Model List

Model Number	Input Voltage Range	Output Power	Set Output Voltage	Output Current Min	Output Current Max	
BLD-320-V048-XYZ-ADJ000	90 ~ 305 Vac	240 W	24V (Default)	0	10A	
		320 W	36V	0	8.9A	
		320 W	48V	0	6.7A	
XY=	Dimming Method	Programmable	12Vaux	Dim-off Power		
NN	-	-	-	-	-	
DN	0-10V+PWM	-	-	-	<0.5W	
AN	DALI2.0+PUSH	-	-	-	<0.5W	
Z=	U	V	S	S-GLB000	W	D
Input Cable	3 pin UL cable with ground	3 pin UL cable with ground	3 pin VDE cable with ground	3 pin Global cable with ground	3 pin VDE cable with ground	2 pin VDE cable without ground
Output Cable	2 pin UL cable without Ground	3 pin UL cable with ground	2 pin VDE cable without ground	2 pin Global cable with ground	3 pin VDE cable with ground	2 pin VDE cable without ground
Certified Input Voltage Range	UL Listed Class P FCC 120-277Vac	UL Listed Class P FCC 120-277Vac	ENEC CB RCM Class I 220-277Vac	UL Recognized 120-277Vac ENEC CB RCM Class I 220-277Vac	Class I 120-277Vac	ENEC CB Class II 220-277Vac

Note: Dimmable Drivers Do NOT Support Switching DCDC Regulator as Load

320W, Constant Voltage Adjustable Output LED Driver

■ Technical Data

Input Voltage	90~305Vac, 380Vac for 2 hours
Input Frequency	47~63Hz
Power Factor	>0.9@60-100%load, refer to PF vs. Load curve
THD	<15%@60-100%load, refer to THD vs. Load curve
Input Current	2.9Amax@120Vac & Full-Load, 1.5Amax@220Vac & Full-Load
Inrush Current	See Inrush Current Section in the datasheet
Leakage Current	0.75MIU max @277Vac 60Hz, UL8750 0.7mA max @240Vac 50/60Hz, IEC60598-1
Input Under Voltage	Shut down and auto-restart
Surge Protection	Line to line 6kV, line to ground 4kV, IEC 61000-4-5
Voltage Accuracy	±3%Vo
Voltage Ripple	Vp-p:5%Vo max
Setup Time	1.2s max.
Output Overshoot	10% Vo, max.
Output Over Current	120% Io, typ.
Short Circuit	Auto recovery. The output recovers when short is removed.
Over Temperature	Turn off the output when $T_c \geq 105 \pm 10^\circ\text{C}$; Auto Recovery When $T_c \leq 70 \pm 10^\circ\text{C}$
Operating Temperature	Case Temperature $T_c = -40^\circ\text{C} \sim +90^\circ\text{C}$; 10%RH~100%RH
Storage Temperature	$-40^\circ\text{C} \sim +85^\circ\text{C}$; 5%RH~100%RH
MTBF	$\geq 280,000$ hours, 75°C case temperature (MIL-HDBK-217F)
Lifetime	$\geq 100,000$ hours, 75°C case temperature, refer to life vs. T_c curve
Case Temperature	90°C max, marked in the T_c point of label
Dimensions	8.85x2.66x1.52 by inch (body), 9.88x2.66x1.52 by inch (endcaps included) 225.0x68.0x38.5 by mm (body), 251.0x68.0x38.5 by mm (endcaps included)
Net Weight	1120g
Packing	See Package Information Section in the datasheet

Notes: Unless specified, all the test results are measured in 25°C room temperature.

320W, Constant Voltage Adjustable Output LED Driver

■ Dimming

Parameter	Min.	Typ.	Max.
Vdim Sourcing Current	100uA	150uA	200uA
Vdim Allowed Input Voltage	-20 V		20 V
0-10V Dimming Range	2% (Vdim=1V)	Linear	100% (Vdim=9~10V)
PWM Dimming Range	2% (Duty=10%)	Linear	100% (Duty=90-100%)
Dim off threshold	0.4V or 4%	0.5V or 5%	0.6V or 6%
Dim on threshold	0.6V or 6%	0.7V or 7%	0.8V or 8%
PWM High	9.5V	10V	10.5V
PWM Low	0V		0.6V
PWM Frequency	1kHz		2kHz
External PWM Controller Current Sinking Capability	300uA		
DALI Interface Standard	IEC62386, part 101,102,207		
DA1,DA2 High Level	9.5	16	22.5
DA1,DA2 Low Level	-6.5	0	6.5
DA1,DA2 Current	0		2mA

- Default Dimming Curves

0-10V Dimming Curve

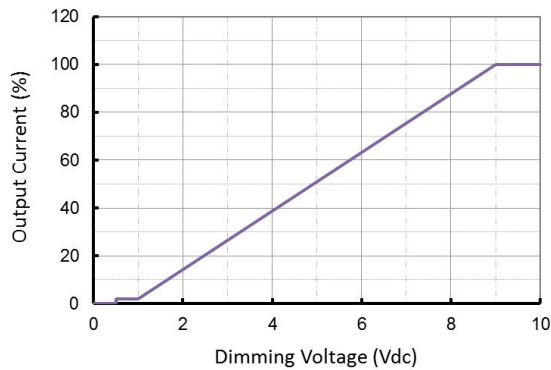

PWM Dimming Curve

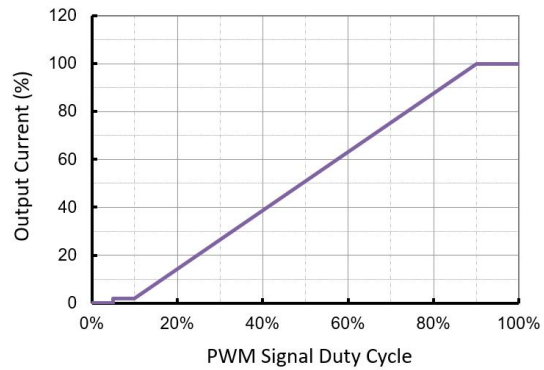

320W, Constant Voltage Adjustable Output LED Driver

DALI Dimming Curve

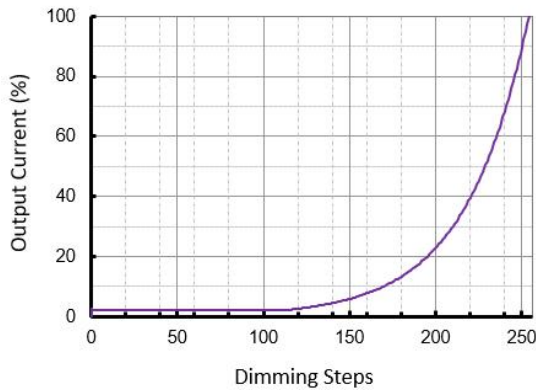

DMX/RDM Dimming Curve

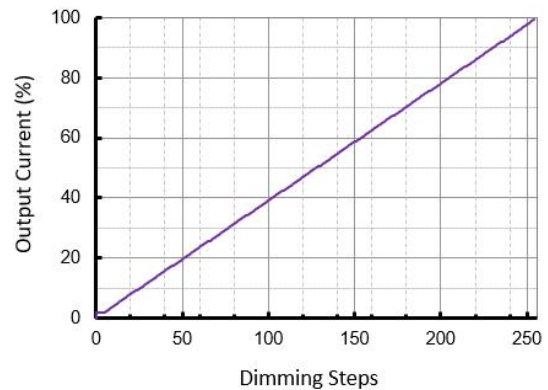

Note: Both DALI and DMX dimming curves can be customized to be linear or logarithmic as default.

- Dimming Wiring

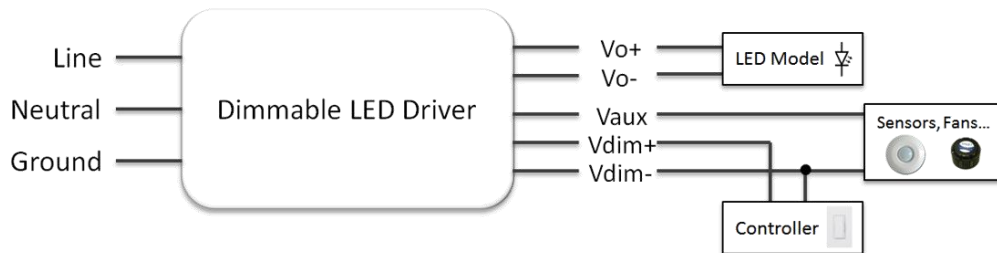

- Push (Switch) Dim

A short press (50-600 ms) switches the device on or off

A long press (> 600 ms) fades the connected operating device alternately up and down (between 2 and 100%). Up and down slew rate is 20%/second.

Long push for 15s to synchronize.

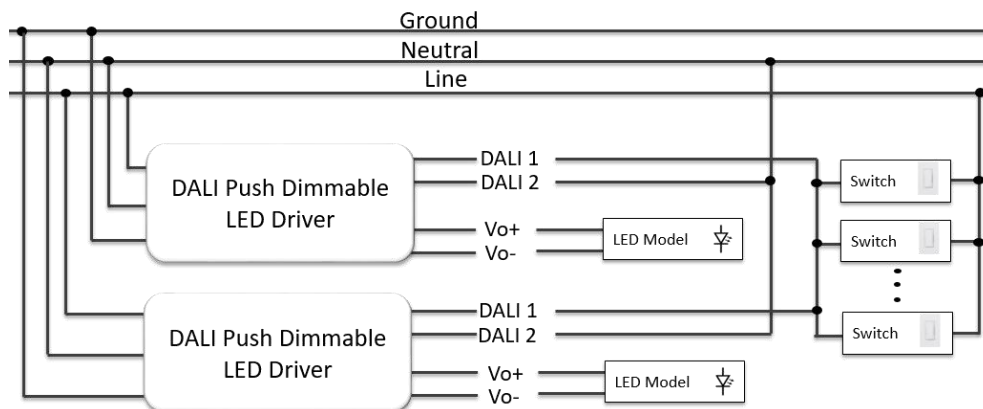

320W, Constant Voltage Adjustable Output LED Driver

Safety/EMC Compliance

Safety Standards	Description
UL8750	Light emitting diode(LED) equipment for use in lighting products
UL1012	Power units other than class 2
IEC 61347-1	Lamp control gear Part 1: general and safety requirements
IEC 61347-2-13	Lamp control gear Part 2-13: particular requirement for d.c. or a.c. supplied electronic control gear for LED modules
IEC 62384	DC or AC supplied electronic control gear for LED modules - Performance requirements
EMC Standards	Description
IEC 55015	Conducted emission test & radiated emission test
IEC 61000-3-2	Harmonic current emissions; Class C
IEC 61000-3-3	Voltage fluctuations & flicker
FCC Part 15	ANSI C63.4:2009 Class B
IEC 61000-4-2	Electrostatic discharge (ESD): 8 kV air discharge, 4 kV contact discharge
IEC 61000-4-3	Radio frequency electromagnetic field susceptibility test (RS)
IEC 61000-4-4	Electrical fast transient (EFT)
IEC 61000-4-5	Surge immunity test
IEC 61000-4-6	Conducted radio frequency disturbances test (CS)
IEC 61000-4-8	Power frequency magnetic field test
IEC 61000-4-11	Voltage dips
IEC 61547	Electromagnetic immunity requirements applies to lighting equipment

Output Voltage Setting by Pushing Button

There is a push button on the end cap to set the output voltage by two different ways.

Long Press (> 600 ms): Two functions as below

1. Activate the output voltage setting mode and the LED indicator keep flashing.
2. Long press to switch the output voltage between 3 preset values as below.

Set Output Voltage	Adjustable Voltage Range	Output Current Power Max	Output Current Max
24V	24-27V	240W	10A
36V	28-40V	320W	Min [320W/Vo, 10A]
48V	41-50V	320W	320W/Vo

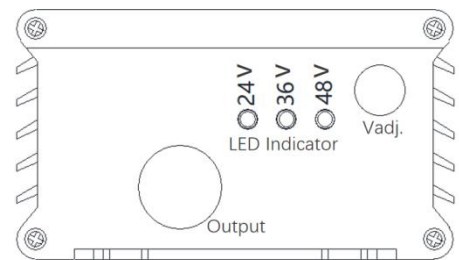

Short Press (50-600 ms) : Slightly adjust the output voltage. The output voltage changes by 0.5V/press recycling in the range listed in the table. For example, if the set voltage is 36V, the output voltage will recycle within 28V and 40V when the button is kept pressing. Please kindly note that the maximum output current is the minimum value between 10A and 320W/Output Voltage. For example, if output voltage is set to 28V, the maximum output current should be the 10A since $320W/28V=11.4A$ is larger than 10A.

■ Lifetime vs. Case Temperature

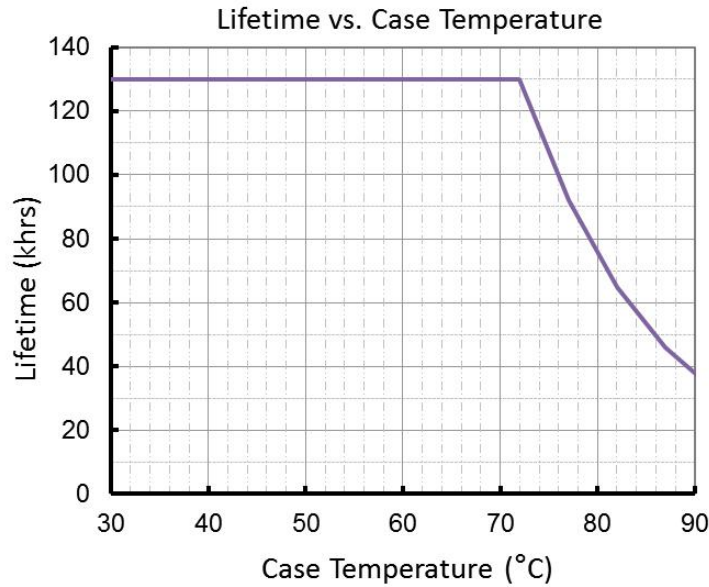

(End of Life: Maximum Failure Rate=10%)

■ Power Factor vs. Load

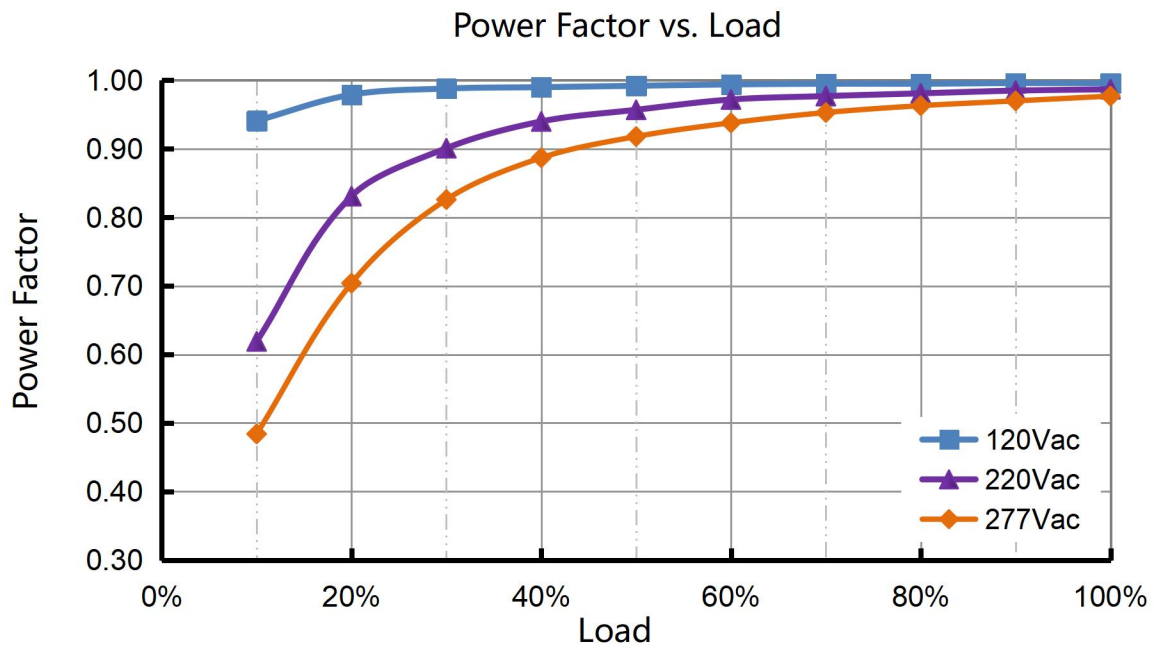

THD vs. Load

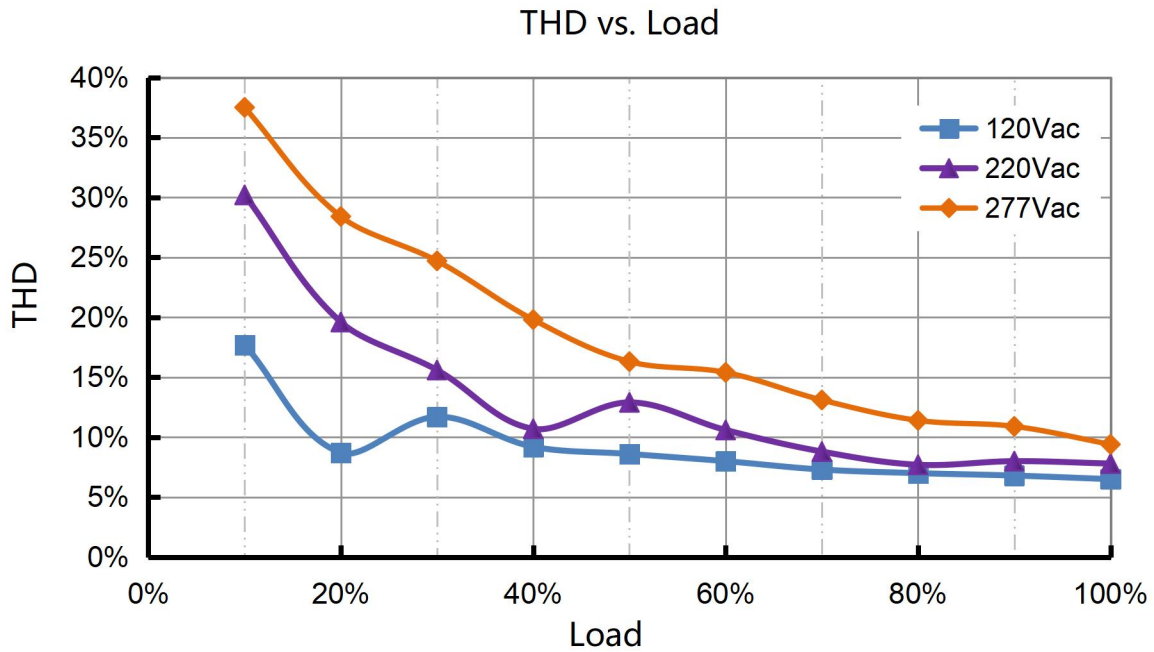

Efficiency vs. Load

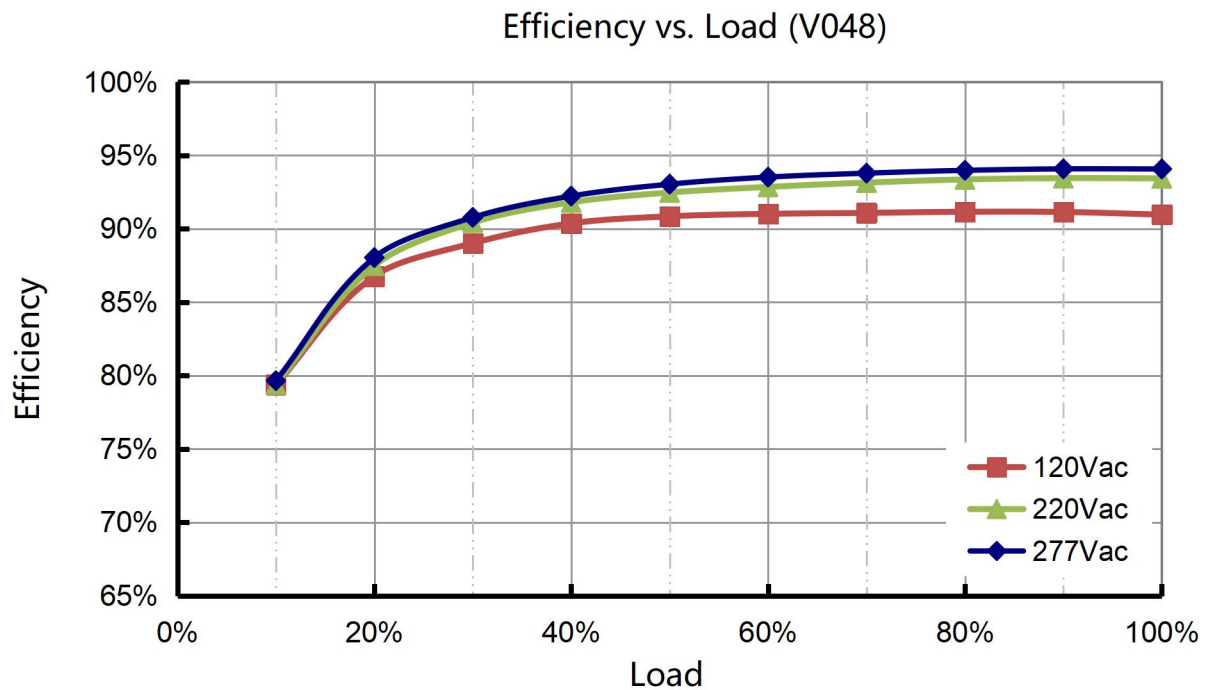

■ Inrush Current

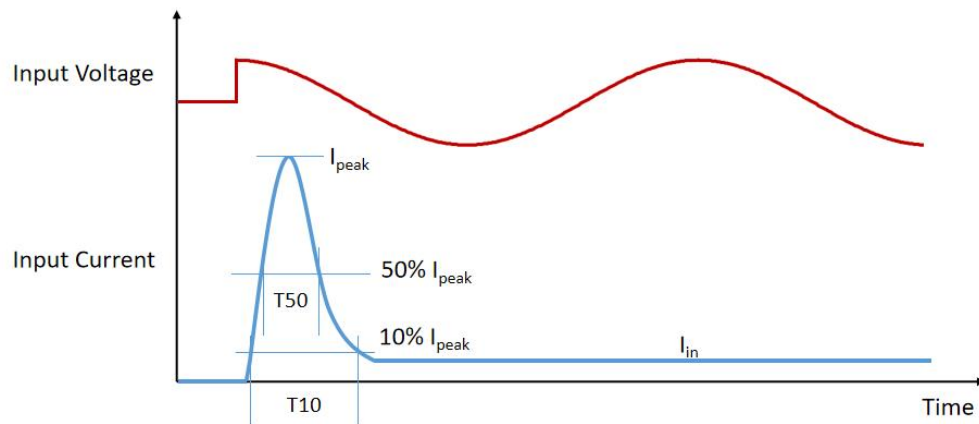

Input Voltage	I_{peak}	10% -10% T10 Duration	50% -50% T50 Duration
120Vac	16.6A	4.28mS	1.4ms
220Vac	31.2A	3.88mS	1.3ms
277Vac	39.8A	3.80mS	1.3ms

- MCB Suggestion

Type	B10	B16	B25	B32	C10	C16	C25	C32	D10	D16	D25	D32
Driver Quantity	1	2	4	5	2	4	7	9	5	8	12	16

Note: Calculated with MCB S200 series manufactured by ABB at 230Vac Input condition

■ Dielectric Strength

Unit: Vac	Input	Output	Dimming	Case
Input	-	3750	3750	1554
Output	3750	-	-	1554
Dimming	3750	-	-	1554
Case	1554	1554	1554	-

■ Tc Point

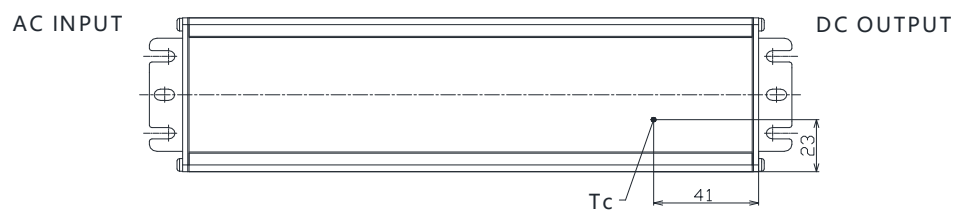

■ Packaging Information

Typical Carton Dimension(L×W×H)	490×370×125 mm
Positioning plate	2pcs/carton
Shield Board	1pcs/carton
LED Drivers/LED	8pcs/carton
Net Weight	9.0 kg/carton
Gross Weight	10.0 kg/carton

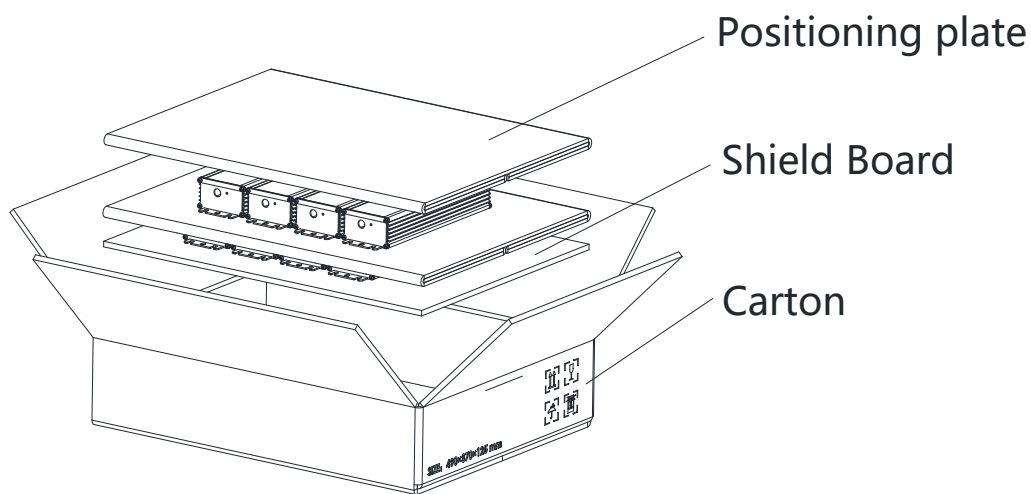

320W, Constant Voltage Adjustable Output LED Driver

Mechanical Design

BLD-320-Vxxx-NNU (UL Cable)

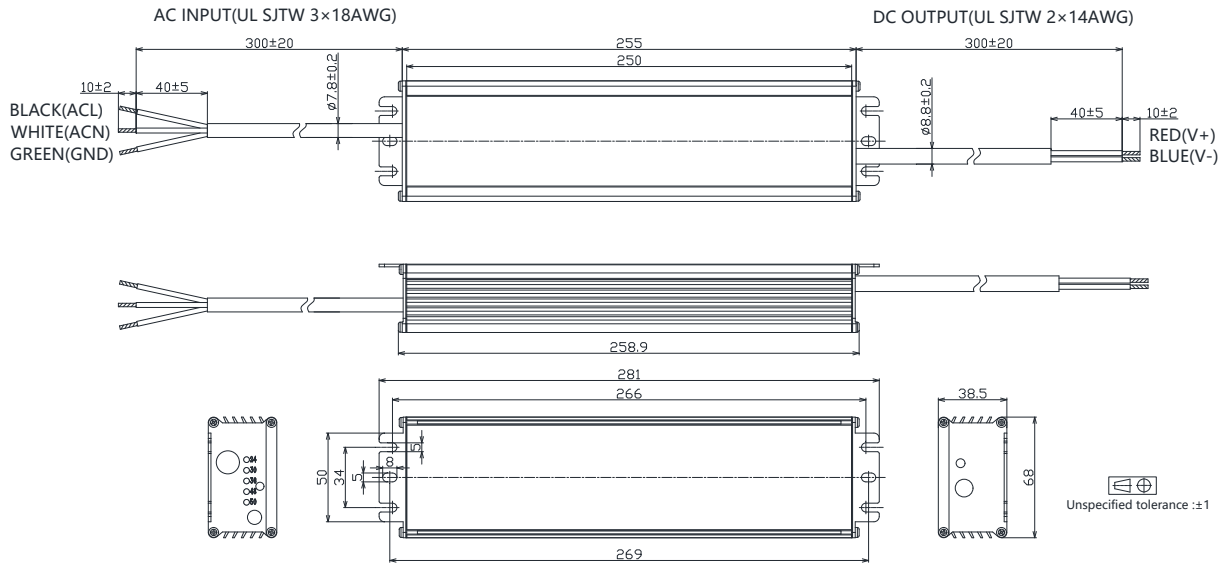

BLD-320-Vxxx-DNU (UL Cable)

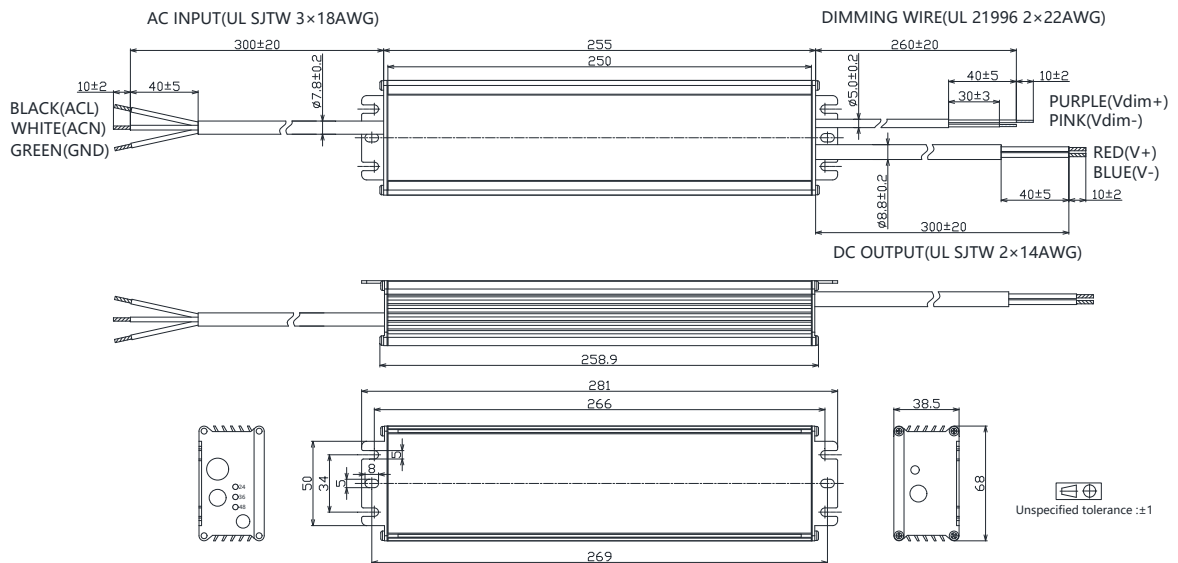

■ Revision History

Revision	Date	Contents
A	2024-12-7	1. New Release